

ACTS-150 Specifications

Basic Tower Construction Materials	
Tower support frame assembly:	-
Casing:	FRP
Casing supporter:	Nylon
Cold water basin:	FRP
Filling:	PVC
Filling support:	PVC
Fan guard:	PP
Mechanical equipment support	HDGS
Air inlet louver:	PVC
Structural Details	
Overall diameter:	130 in
Overall height:	90 in
Dry weight:	1,375 lbs
Operating weight:	5,731 lbs
Total pump head:	10 ft
Design wind load:	30.7 lb/sq ft
Fan Motor	
Number of motors:	one unit per tower
Type:	Induction
Insulation:	E class
Rated HP:	5 h. p.
Voltage and phase:	220/440-3

Piping Connections	
Primary water inlet diameter:	5 in
Primary water outlet diameter:	5 in
Auto fill inlet diameter:	1 in
Quick fill inlet diameter:	- in
Overflow outlet diameter:	2 in
Drain diameter:	2 in
Design and Operating Conditions	
Nominal Tons:	150
Tower type:	Counter Flow Induces Draft
Water flow rates:	318 gpm
Hot water temperature:	95° f
Cold water temperature:	85° f
Ambient wet bulb	75° f
Total fan BHP:	5 h. p.
Drift loss of water flow rates:	0.002%
Evaporation loss of water	0.93%
Mechanical Equipment	
Fan unit:	one unit per tower
Type:	Axial Flow
Diameter:	69 in
Blade material:	AC
Hub material:	AC
Nominal air volume:	33,260 cfm

Assembly Diagram

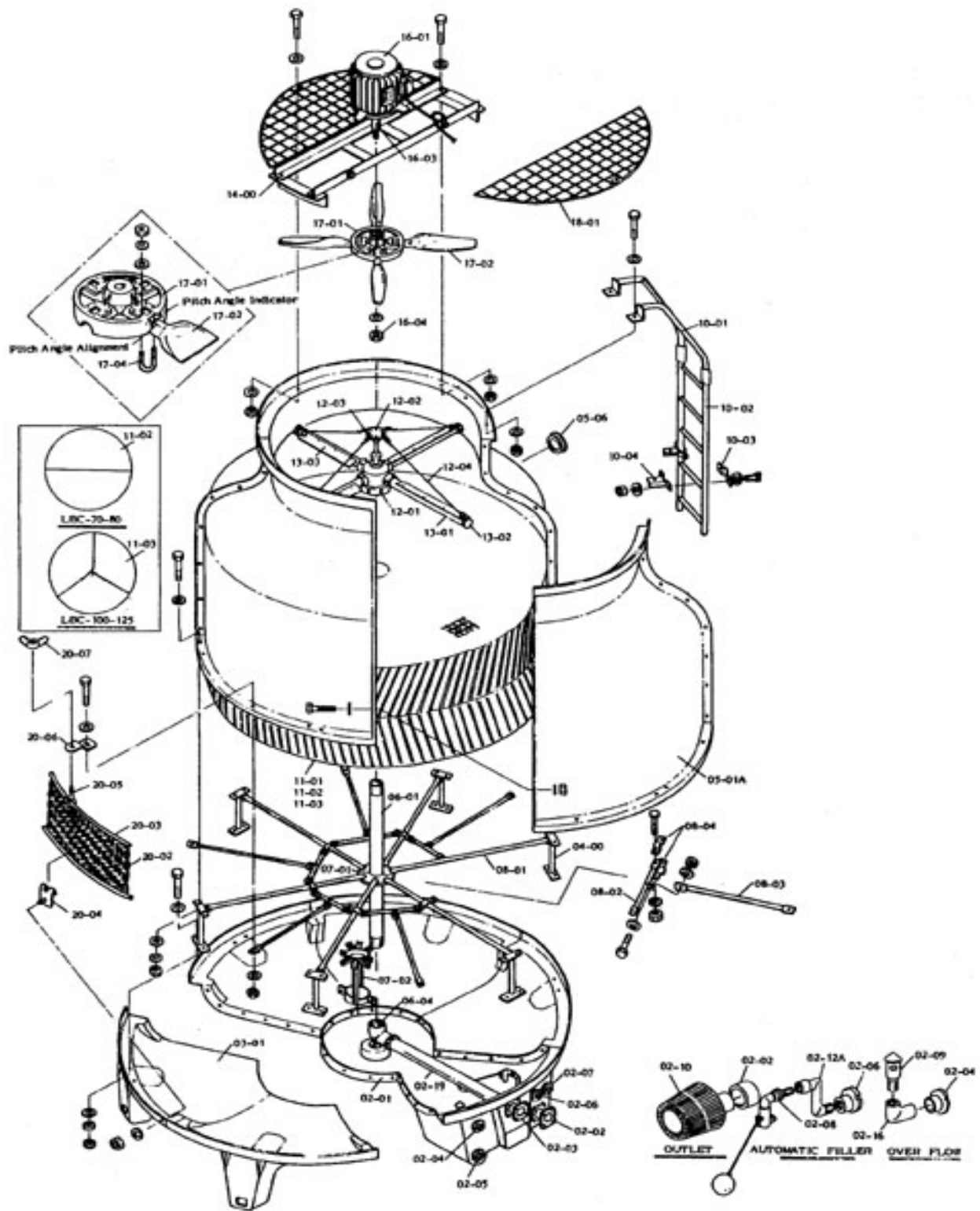

American Chillers & Cooling Tower Systems

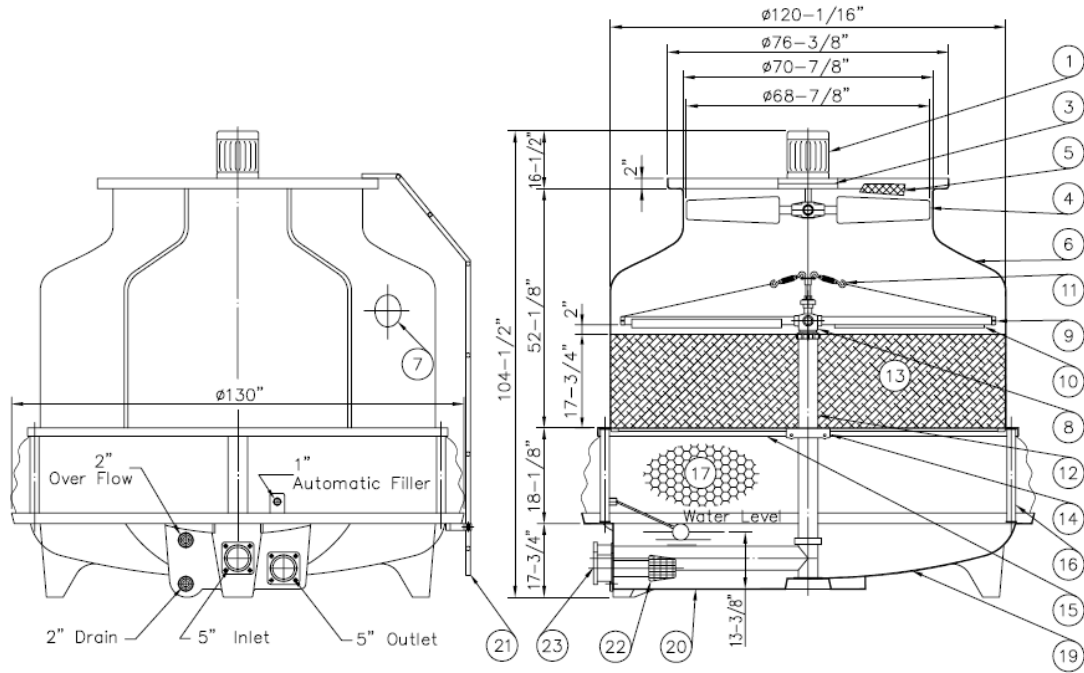

Item No.	Description	Qty
1	Fan Motor	1 pcs
2	V-Belt Reducer	-
3	Motor Frame Assembly	1 set
4	Fan	1 set
5	Fan Guard	1 set
6	Casing	6 pcs
7	Hand Hole	1 pcs
8	Sprinkler Head	1 set
9	Sprinkler Pipe	4 pcs
10	Eliminator	4 pcs
11	Tension Device	4 set
12	Stand Pipe	1 set

Item No.	Description	Qty
13	Filling	1 set
14	Stopper or Column	1 set
15	Filling Supporter	1 set
16	Casing Supporter	6 pcs
17	Inlet Louver	1 set
18	Frame Assembly	-
19	Water Basin	5 pcs
20	Water Sump	1 pcs
21	Ladder	1 set
22	Strainer	1 pcs
23	Flange	2 pcs
24	Basin Supporter	-

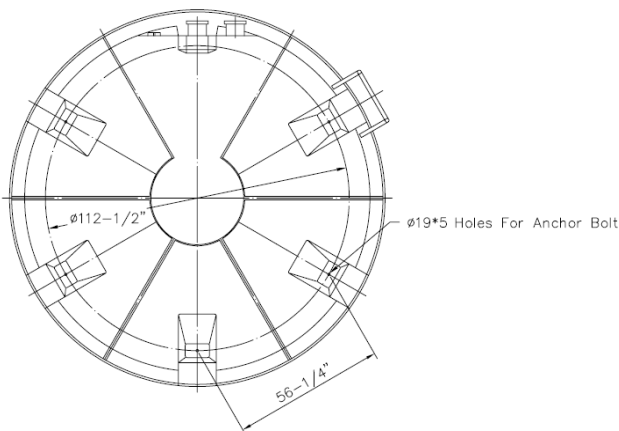

Measurement	Distance (Inches)
D1	112.5
W	56.25
B	12
A	-
h	12
h1	13.5
C	16
D2	-
Anchor Bolt	
Size (In.)	Length (In.)
0.625	8