

ACTS-20 Specifications

Basic Tower Construction Materials	
Tower support frame assembly:	-
Casing:	FRP
Casing supporter:	Nylon
Cold water basin:	FRP
Filling:	PVC
Filling support:	PVC
Fan guard:	PP
Mechanical equipment support	HDGS
Air inlet louver:	PVC
Structural Details	
Overall diameter:	54 in
Overall height:	63 in
Dry weight:	190 lbs
Operating weight:	719 lbs
Total pump head:	5.6 ft
Design wind load:	30.7 lb/sq ft
Fan Motor	
Number of motors:	one unit per tower
Type:	Induction
Insulation:	E class
Rated HP:	.5 h. p.
Voltage and phase:	110/220-1 or 220/440-3

Piping Connections	
Primary water inlet diameter:	2 in
Primary water outlet diameter:	2 in
Auto fill inlet diameter:	0.5 in
Quick fill inlet diameter:	- in
Overflow outlet diameter:	1 in
Drain diameter:	1 in
Design and Operating Conditions	
Nominal Tons:	20
Tower type:	Counter Flow Induces Draft
Water flow rates:	40 gpm
Hot water temperature:	95° f
Cold water temperature:	85° f
Ambient wet bulb temperature:	75° f
Total fan BHP:	.5 h. p.
Drift loss of water flow rates:	0.002%
Evaporation loss of water flow rates:	0.93%
Mechanical Equipment	
Fan unit:	one unit per tower
Type:	Axial Flow
Diameter:	30 in
Blade material:	Nylon
Hub material:	Nylon
Nominal air volume:	6,300 cfm

American Chillers & Cooling Tower Systems

Assembly Diagram

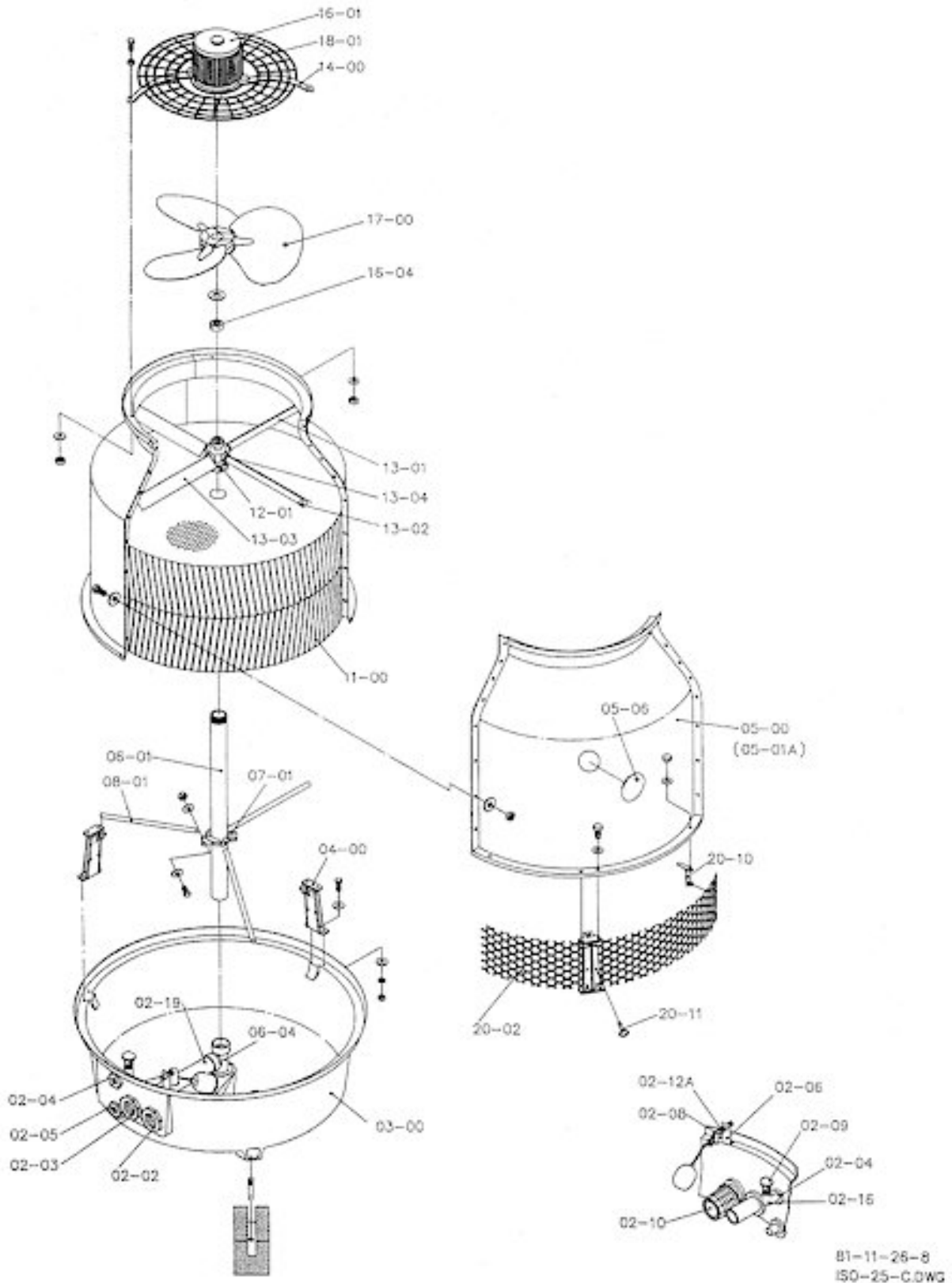

American Chillers & Cooling Tower Systems

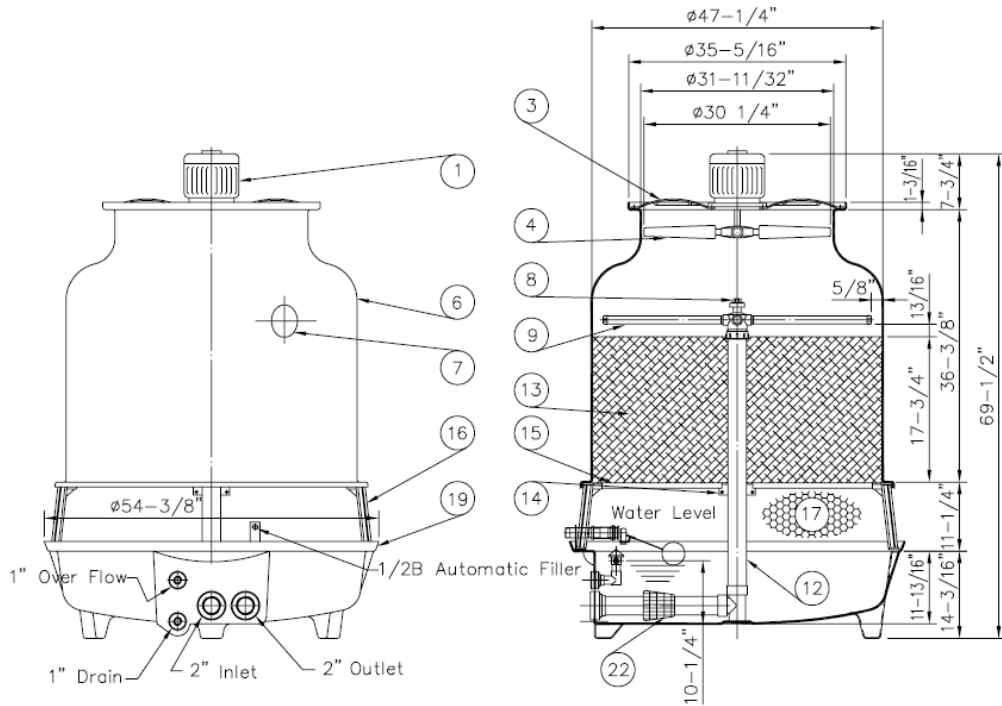

Item No.	Description	Qty
1	Fan Motor	1 pcs
2	V-Belt Reducer	-
3	Motor Frame Assembly	1 set
4	Fan	1 set
5	Fan Guard	-
6	Casing	3 pcs
7	Hand Hole	1 pcs
8	Sprinkler Head	1 set
9	Sprinkler Pipe	4 pcs
10	Eliminator	-
11	Tension Device	-
12	Stand Pipe	1 set

Item No.	Description	Qty
13	Filling	1 set
14	Stopper or Columnn	1 set
15	Filling Supporter	1 set
16	Casing Supporter	3 pcs
17	Inlet Louver	1 set
18	Frame Assembly	-
19	Water Basin	1 pcs
20	Water Sump	-
21	Ladder	-
22	Strainer	1 pcs
23	Flange	-
24	Basin Supporter	-

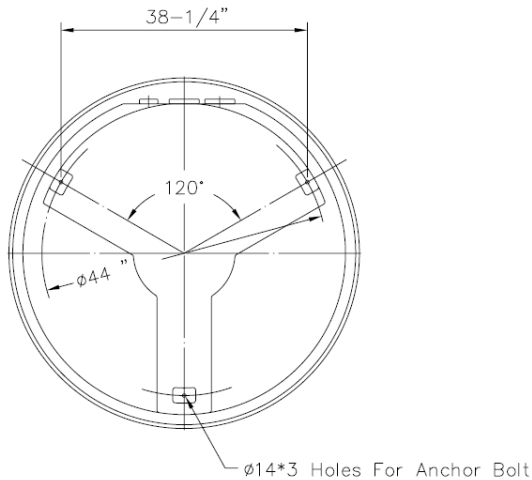

Measurement	Distance (Inches)
D1	44
W	38.25
B	8
A	-
h	6
h1	-
C	-
D2	-
Anchor Bolt	
Size (In.)	Length (In.)
0.50	4.75