

ACTS-350 Specifications

Basic Tower Construction Materials	
Tower support frame assembly:	-
Casing:	FRP
Casing supporter:	Nylon
Cold water basin:	FRP
Filling:	PVC
Filling support:	PVC
Fan guard:	PP
Mechanical equipment support	HDGS
Air inlet louver:	PVC
Structural Details	
Overall diameter:	189 in
Overall height:	134 in
Dry weight:	2,996 lbs
Operating weight:	10,164 lbs
Total pump head:	13.2 ft
Design wind load:	30.7 lb/sq ft
Fan Motor	
Number of motors:	one unit per tower
Type:	Induction
Insulation:	E class
Rated HP:	10 h. p.
Voltage and phase:	220/440-3

Piping Connections	
Primary water inlet diameter:	8 in
Primary water outlet diameter:	8 in
Auto fill inlet diameter:	1.25 in
Quick fill inlet diameter:	1.25 in
Overflow outlet diameter:	2 in
Drain diameter:	2 in
Design and Operating Conditions	
Nominal Tons:	300
Tower type:	Counter Flow
Water flow rates:	744 gpm
Hot water temperature:	95° f
Cold water temperature:	85° f
Ambient wet bulb	75° f
Total fan BHP:	10 h. p.
Drift loss of water flow rates:	0.002%
Evaporation loss of water	0.93%
Mechanical Equipment	
Fan unit:	one unit per
Type:	Axial Flow
Diameter:	93 in
Blade material:	AC
Hub material:	AC
Nominal air volume:	77,020 cfm

Assembly Diagram

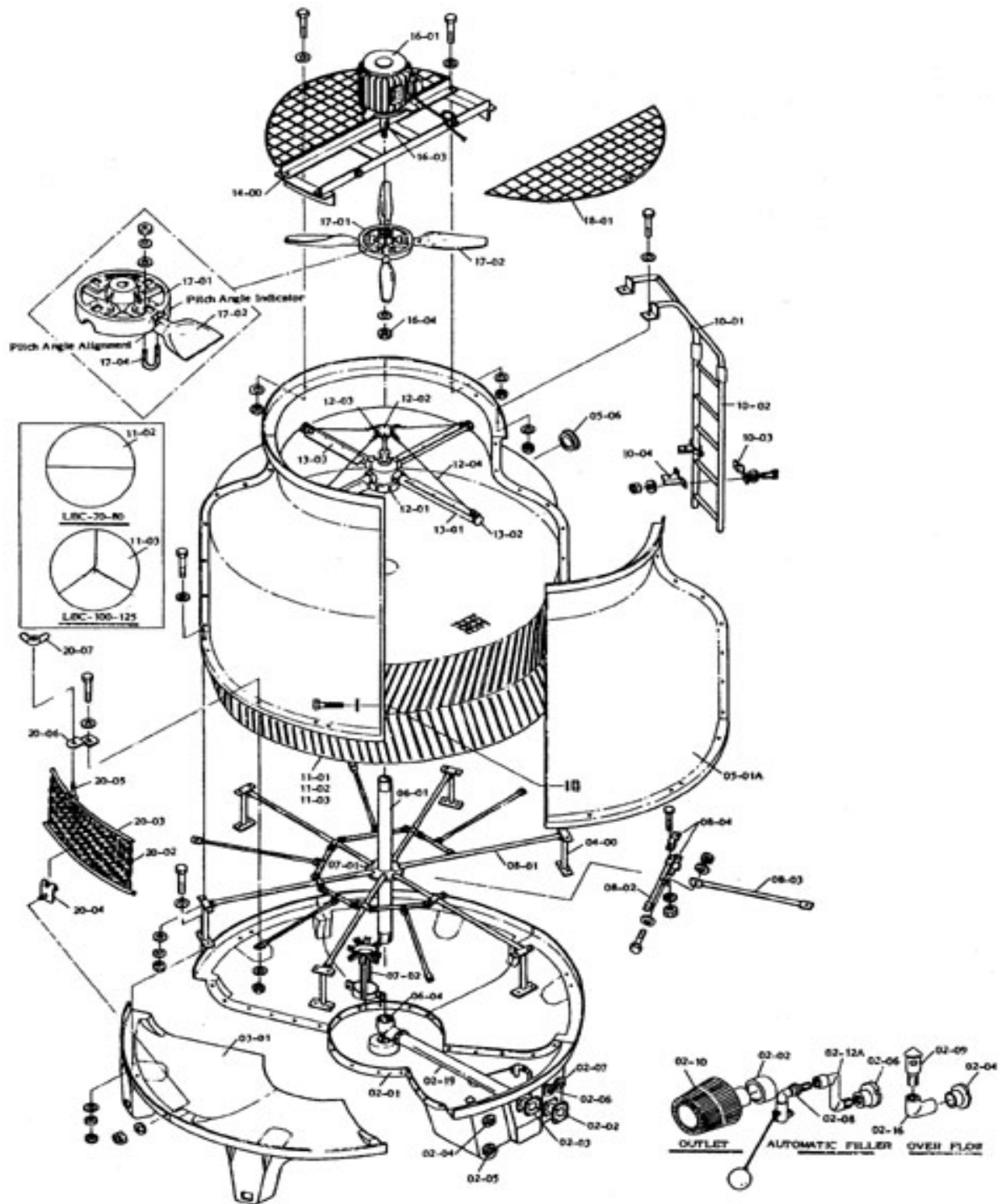

American Chillers & Cooling Tower Systems

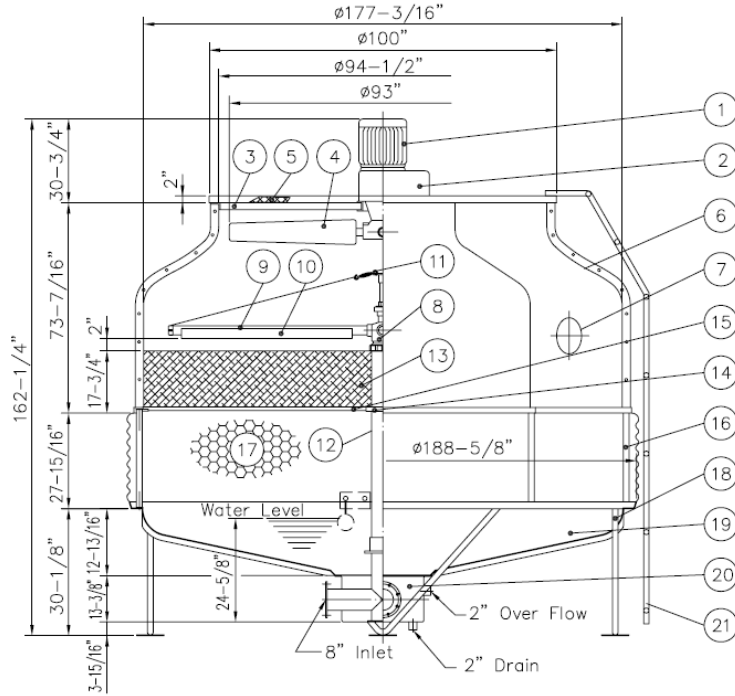

Item No.	Description	Qty
1	Fan Motor	1 pcs
2	V-Belt Reducer	1 set
3	Motor Frame Assembly	1 set
4	Fan	1 set
5	Fan Guard	1 set
6	Casing	8 pcs
7	Hand Hole	1 pcs
8	Sprinkler Head	1 set
9	Sprinkler Pipe	6 pcs
10	Eliminator	6 pcs
11	Tension Device	6 set
12	Stand Pipe	1 set

Item No.	Description	Qty
13	Filling	1 set
14	Stopper or Column	1 set
15	Filling Supporter	1 set
16	Casing Supporter	8 pcs
17	Inlet Louver	1 set
18	Frame Assembly	1 set
19	Water Basin	8 pcs
20	Water Sump	1 pcs
21	Ladder	1 set
22	Strainer	1 pcs
23	Flange	2 pcs
24	Basin Supporter	-

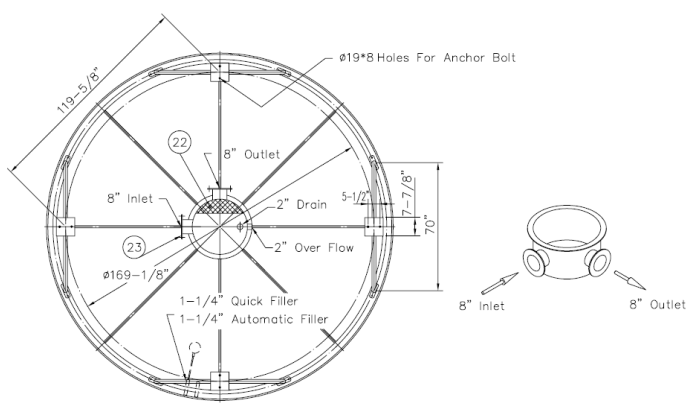

Measurement	Distance (Inches)
D1	169.125
W	119.625
B	12
A	5.5
h	12
h1	16
C	23
D2	-
Anchor Bolt	
Size (In.)	Length (In.)
0.625	8