

ACTS-5 Specifications

Basic Tower Construction Materials	
Tower support frame assembly:	-
Casing:	FRP
Casing supporter:	Nylon
Cold water basin:	FRP
Filling:	PVC
Filling support:	PVC
Fan guard:	PP
Mechanical equipment support	HDGS
Air inlet louver:	PVC
Structural Details	
Overall diameter:	33.5 in
Overall height:	52 in
Dry weight:	86 lbs
Operating weight:	251 lbs
Total pump head:	5 ft
Design wind load:	30.7 lb/sq ft
Fan Motor	
Number of motors:	one unit per tower
Type:	Induction
Insulation:	E class
Rated HP:	1/6 h. p.
Voltage and phase:	110/220-1

Piping Connections	
Primary water inlet diameter:	1.5 in
Primary water outlet diameter:	1.5 in
Auto fill inlet diameter:	0.5 in
Quick fill inlet diameter:	- in
Overflow outlet diameter:	1 in
Drain diameter:	0.75 in
Design and Operating Conditions	
Nominal Tons:	5
Tower type:	Counter Flow
Water flow rates:	10 gpm
Hot water temperature:	95° f
Cold water temperature:	85° f
Ambient wet bulb	75° f
Total fan BHP:	1/6 h. p.
Drift loss of water flow rates:	0.002%
Evaporation loss of water	0.93%
Mechanical Equipment	
Fan unit:	one unit per
Type:	Axial Flow
Diameter:	19.5 in
Blade material:	Nylon
Hub material:	Nylon
Nominal air volume:	2,100 cfm

American Chillers & Cooling Tower Systems

Assembly Diagram

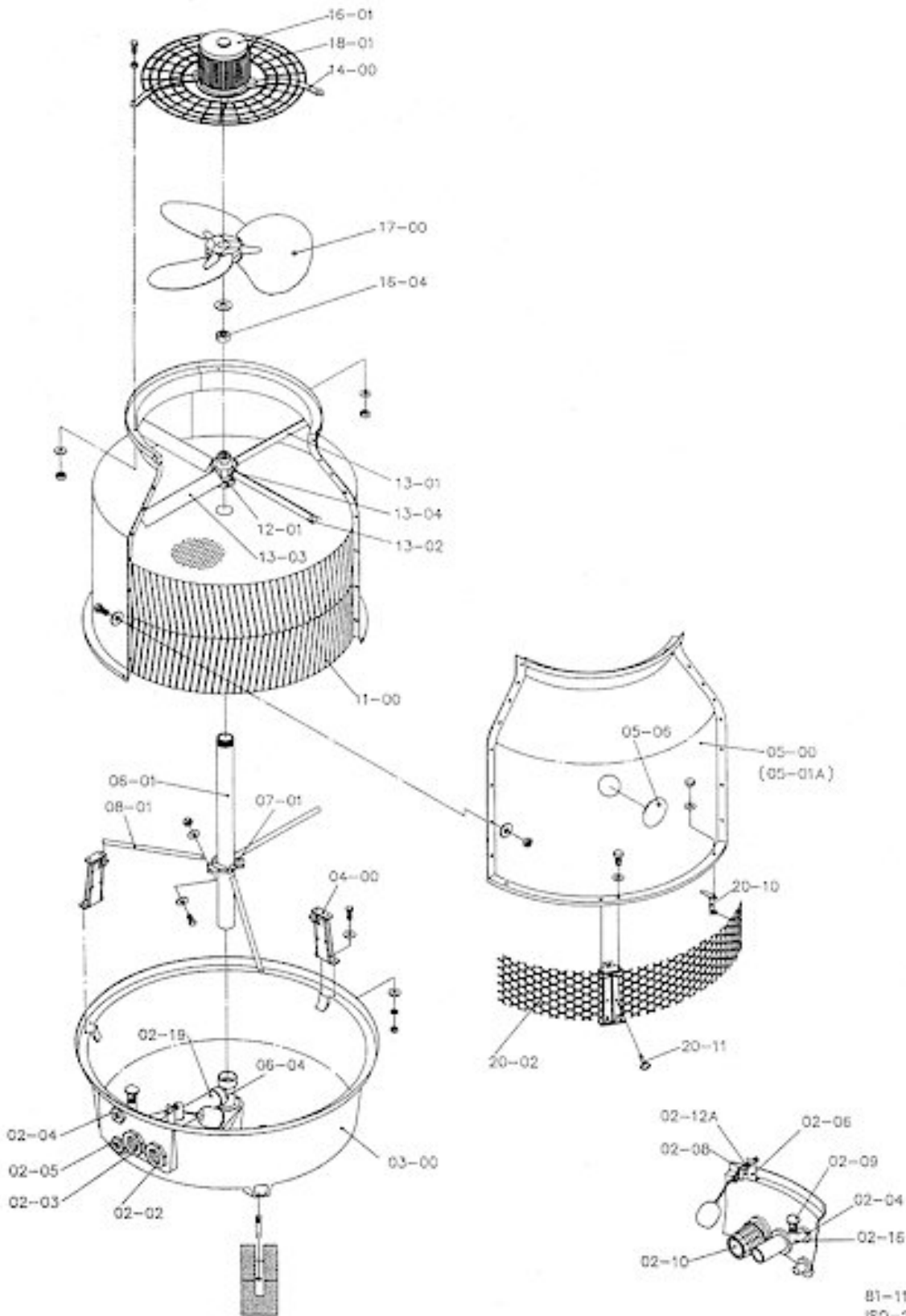

American Chillers & Cooling Tower Systems

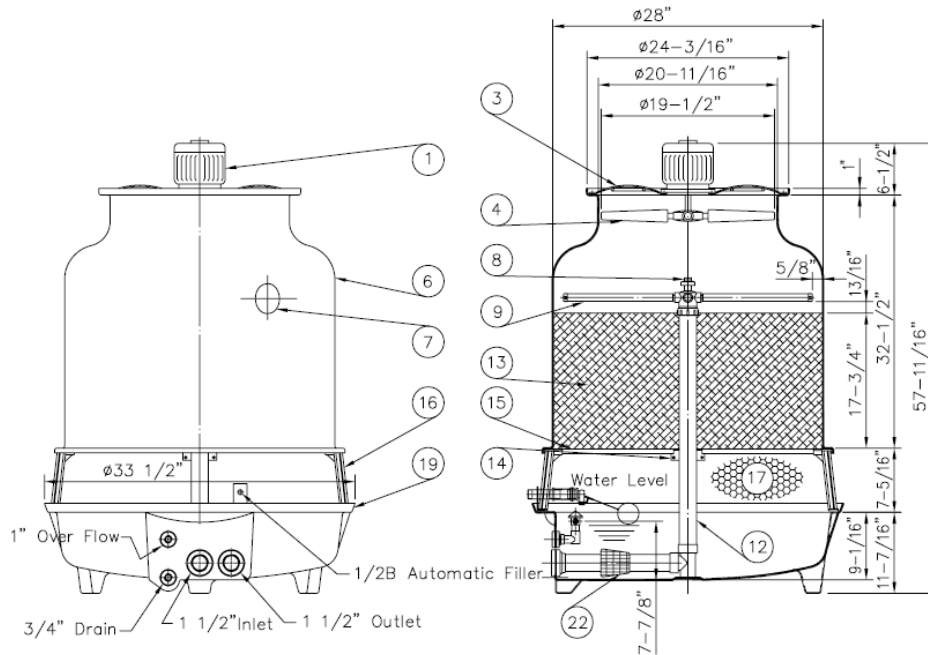

Item No.	Description	Qty
1	Fan Motor	1 pcs
2	V-Belt Reducer	-
3	Motor Frame Assembly	1 set
4	Fan	1 set
5	Fan Guard	-
6	Casing	3 pcs
7	Hand Hole	1 pcs
8	Sprinkler Head	1 set
9	Sprinkler Pipe	4 pcs
10	Eliminator	-
11	Tension Device	-
12	Stand Pipe	1 set

Item No.	Description	Qty
13	Filling	1 set
14	Stopper or Column	1 set
15	Filling Supporter	1 set
16	Casing Supporter	3 pcs
17	Inlet Louver	1 set
18	Frame Assembly	-
19	Water Basin	1 pcs
20	Water Sump	-
21	Ladder	-
22	Strainer	1 pcs
23	Flange	-
24	Basin Supporter	-

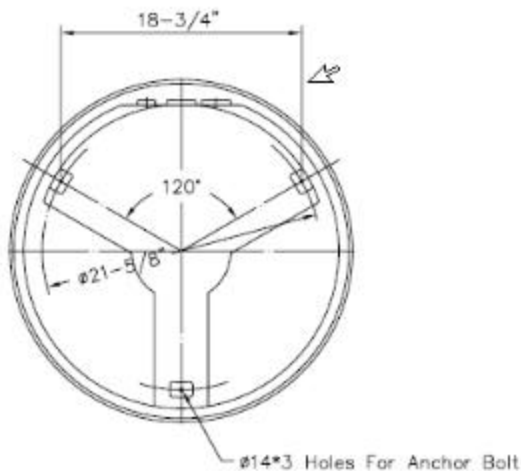

Measurement	Distance (Inches)
D1	21.625
W	18.75
B	8
A	-
h	6
h1	-
C	-
D2	-
Anchor Bolt	
Size (In.)	Length (In.)
0.50	4.75