

ACTS-800 Specifications

Basic Tower Construction Materials	
Tower support frame assembly:	-
Casing:	FRP
Casing supporter:	Nylon
Cold water basin:	FRP
Filling:	PVC
Filling support:	PVC
Fan guard:	PP
Mechanical equipment support	HDGS
Air inlet louver:	PVC
Structural Details	
Overall diameter:	299 in
Overall height:	194 in
Dry weight:	9,636 lbs
Operating weight:	26,356 lbs
Total pump head:	20 ft
Design wind load:	30.7 lb/sq ft
Fan Motor	
Number of motors:	one unit per tower
Type:	Induction
Insulation:	E class
Rated HP:	30 h. p.
Voltage and phase:	220/440-3

Piping Connections	
Primary water inlet diameter:	12 in
Primary water outlet diameter:	12 in
Auto fill inlet diameter:	2 in
Quick fill inlet diameter:	2 in
Overflow outlet diameter:	4 in
Drain diameter:	3 in
Design and Operating Conditions	
Nominal Tons:	800
Tower type:	Counter Flow Induces Draft
Water flow rates:	1,703 gpm
Hot water temperature:	95° f
Cold water temperature:	85° f
Ambient wet bulb	75° f
Total fan BHP:	30 h. p.
Drift loss of water flow rates:	0.002%
Evaporation loss of water	0.93%
Mechanical Equipment	
Fan unit:	one unit per tower
Type:	Axial Flow
Diameter:	141 in
Blade material:	AC
Hub material:	AC
Nominal air volume:	175,000 cfm

Assembly Diagram

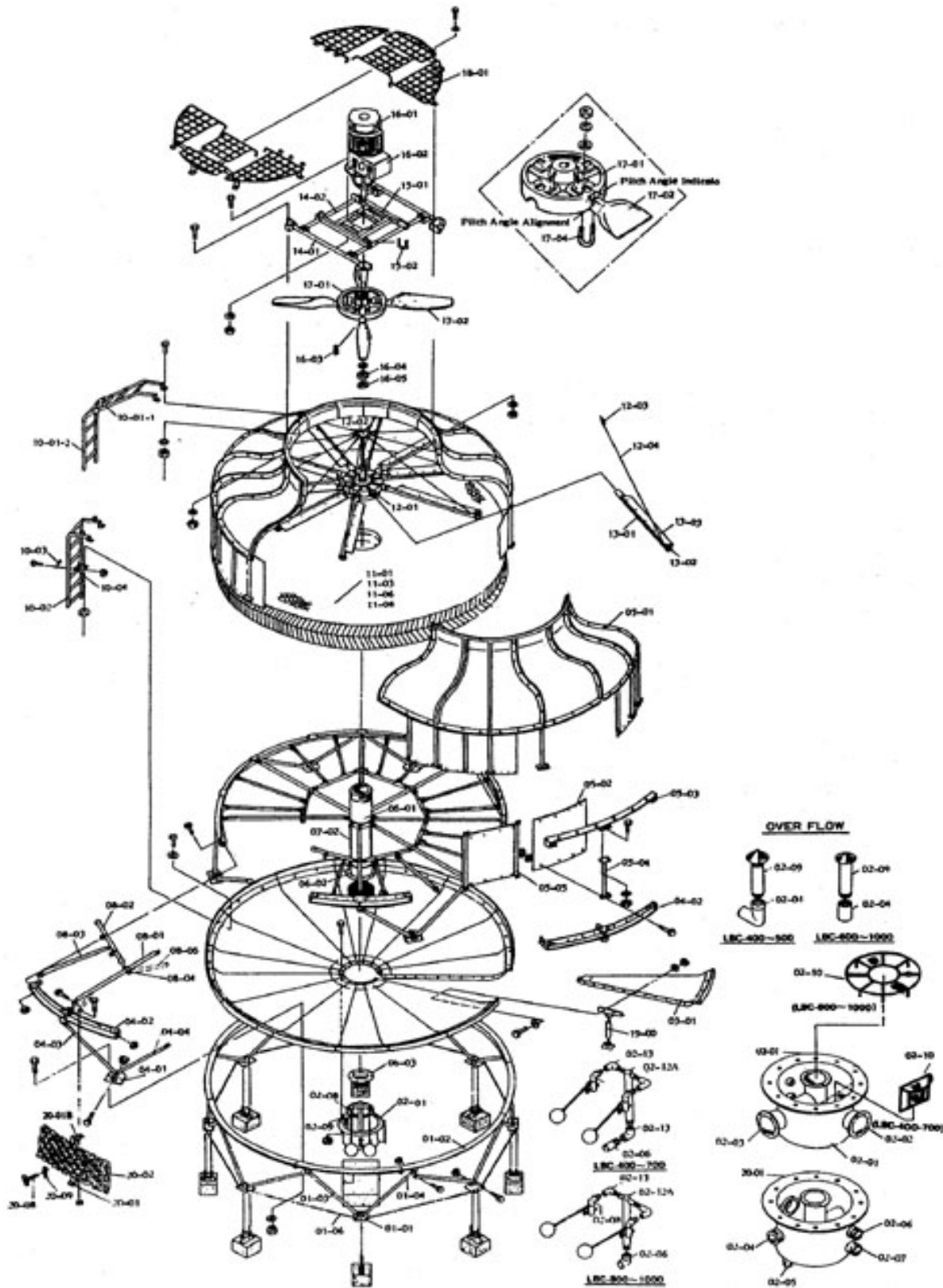

American Chillers & Cooling Tower Systems

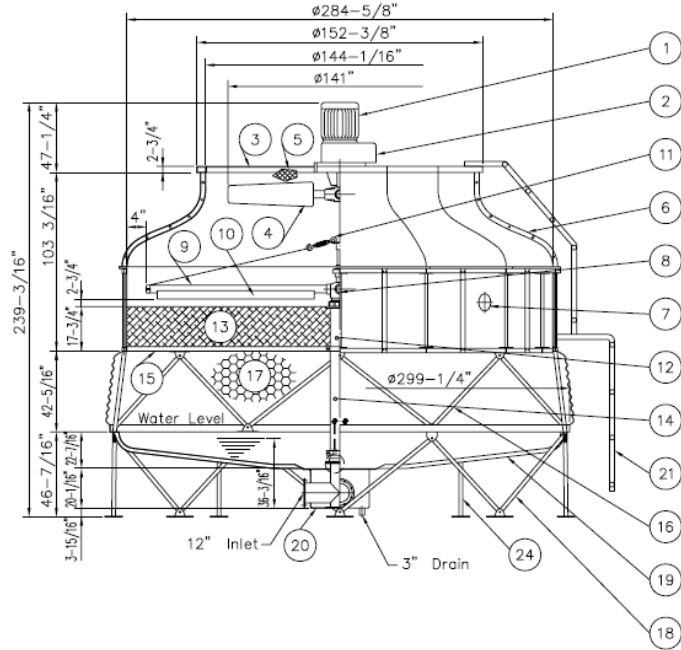

Item No.	Description	Qty
1	Fan Motor	1 pcs
2	V-Belt Reducer	1 set
3	Motor Frame Assembly	1 set
4	Fan	1 set
5	Fan Guard	1 set
6	Casing	16 pcs
7	Hand Hole	1 pcs
8	Sprinkler Head	1 set
9	Sprinkler Pipe	10 pcs
10	Eliminator	10 pcs
11	Tension Device	10 set
12	Stand Pipe	1 set

Item No.	Description	Qty
13	Filling	1 set
14	Stopper or Column	1 set
15	Filling Supporter	1 set
16	Casing Supporter	8 pcs
17	Inlet Louver	1 set
18	Frame Assembly	1 set
19	Water Basin	16 pcs
20	Water Sump	1 pcs
21	Ladder	1 set
22	Strainer	1 pcs
23	Flange	2 pcs
24	Basin Supporter	16 pcs

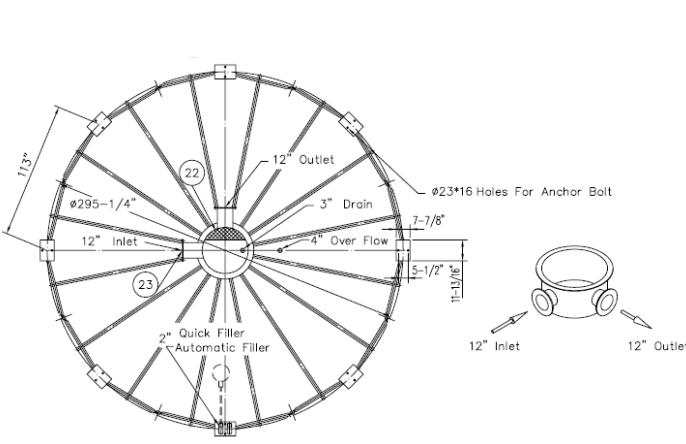

Measurement	Distance (Inches)
D1	295.25
W	113
B	20
A	5.5
h	12
h1	16
C	31.5
D2	163.5
Anchor Bolt	
Size (In.)	Length (In.)
0.75	8